

# Rockin' Crystals

An engineering-themed activity pack for National Science & Engineering Week.

For more information on National Science and Engineering Week or for further activity packs, please visit [www.nsew.org.uk](http://www.nsew.org.uk)



# The big challenge: putting on a show

Your big challenge is to put on a show – either a live stage show or a recorded television show – to give a theatrical Earth science demonstration. By working together as a group, you can each focus on one thing and come together to share ideas and put on the show.

First, you have to decide on what to include. Below are some possibilities. They include experiments with crystals, rocks and some interesting wire! They all present their own little challenges ...

---

## Organiser's introduction 2

---

## Crystals, rocks and engineering 4

---

## Growing crystals 7

1. Crystals from melts
2. Crystals from vapour
3. Crystals from solutions – by evaporation
4. Crystals from solutions – using electricity
5. Who can grow the largest crystal from solution?

---

## Modelling crystals 15

1. Modelling a salt crystal using marshmallows
2. Modelling crystals using cardboard shapes
3. Modelling diamond and graphite
4. Modelling crystal growth using people

---

## More about crystals 21

1. Crystalline or plastic?
2. Make a crystal garden

---

## Putting crystals to use 27

1. Crystals and microphones (and physical weathering)
2. Memory metal
3. Lift with a spring

## Organiser's introduction

Mostly for 11-13 year olds, these activities will also suit 14-16 year olds. Organisers will need to consider the ability range of their particular students. Most of the activities require the use of a science laboratory and its equipment.

Any one of the activities can be carried out on a stand alone basis, for use in part of a session. If more time is available, organisers might select a set of activities, based on materials and equipment to hand, for the students to create their show.

Crystals, and the crystalline structure of many materials, play an important part in many aspects of engineering – engineers need to understand their nature in order to deal with the opportunities and the problems that they present. Materials science is the analysis of materials and the development of new ones. To create buildings, electronics, electrical products, mechanical items, textiles, food and chemicals – in fact, almost everything that supports daily life - engineers make use of this knowledge.

Students should have a definite timescale and set themselves clear objectives. They should also set themselves intermediate goals and, as soon as possible, complete any trials so they can decide if they want to change their minds about what they are going to include in their show.

If they decide to use video material, they could have a look at some of the recordings to be found on the internet (for example at <http://sciencehack.com/videos/category/2>), so they can gain an idea of what kinds of things work and what to try to avoid.

At an early stage, they should decide who they are going to perform for and take into account any introductions or background that they might want to use to set the scene for their demonstrations. The audience may need some things explaining to them.

They should also consider the viewing needs of an audience. Will things show up on a small screen? Will everyone in a live audience be able to see and hear everything? Would use of CCTV or a public address system help?

At least one full rehearsal will reveal any major problems that may need to be tackled.

Background on crystals can be found at [http://www.chymist.com/alum\\_crystals.pdf](http://www.chymist.com/alum_crystals.pdf)

## CREST Awards

### Could your students gain a CREST Award?

By extending the activities included here, or communicating them as part of a project, students could gain a CREST Bronze or maybe even a Silver Award.

**CREST is Britain's largest national award scheme** for project work in the STEM subjects (Science, Technology, Engineering and Mathematics). It gives young people aged 11-19 opportunities to explore **real world projects** in an exciting way. CREST **links closely to the curriculum** and is a great way to make STEM **creative and engaging** – both in and out of the class.

**CREST Awards are extremely flexible** – they can link into **work experience placements**, after-school clubs or several **linked schemes**. Some projects might be done in one day – others over several months. Students can **investigate** or **design and make, research** a subject, or design a **science communication** project.

CREST Awards are available at Bronze, Silver and Gold levels, depending on the amount and depth of work the student carries out. Bronze Awards need around 10 hours of project work and are usually completed by 11 to 14 year-olds.

In taking part in activities from this booklet students will already be demonstrating many of the skills they need to obtain a CREST Award, including working systematically, solving problems creatively

and presenting work to others. Students participating in the 'Rockin' Crystals' activities may therefore be eligible to apply for a CREST Bronze Award. A CREST awards logo is used in the booklet next to sections which might provide ideas for a CREST award.

It is worth linking activities with a CREST Award for several reasons:

- It is a way of having project work recognised nationally – a Bronze CREST Award is a significant achievement.
- It provides evidence of problem-solving skills and motivates students to go on to CREST at Silver and Gold level.
- It can form part of a Progress File and can help with university applications later on.
- It motivates students of all ages and abilities.
- It develops students' understanding of 'how science works', preparing them for GCSE studies.

#### **What do I/we need to do?**

You can register your students for the Bronze CREST Awards through your local CREST coordinator. For more information and contact details call the British Science Association on 020 7019 4943 or go to [www.britishsociety.org/crest](http://www.britishsociety.org/crest)

## **Health and Safety**

A risk assessment should always be carried out before starting any practical work.

Most of these practical activities involve scientific apparatus and procedures. They should be carried out in a school laboratory, with full supervision of the students. The three ideas for **Modelling crystals** could be carried out elsewhere, although supervision is still required.

# Crystals, rocks and engineering

Why do scientists and engineers need to know about crystals?

## Talk about ...

- What is a crystal? How do you know one when you see it?
- Where have you seen crystals?
- What properties do they have in common?
- Are crystals all the same size and shape?
- How are they different from one another?
- Why might scientists and engineers need to know about crystals?

# Crystals, rocks and engineering

## ORGANISER'S NOTES

### What do I do?

1. Read through the activity instruction sheet to familiarise yourself with the questions.
2. Check the resources list and make sure that everything that students need is available. Extra materials may be needed if trial runs or repeats are necessary.
3. Make sure that students understand the activity – to understand why crystals are important to engineers.
4. Optional: students can be asked to examine and discuss examples of crystals and crystalline and non- crystalline materials.
  - Challenge students to separate examples into crystals and non-crystals and to write their own definition of what a crystal is.
  - Have students critically evaluate each others' definitions.
  - Use ball and stick models or diagrams of crystal structures to show how crystals are made up of particles which are arranged in a regular repeating pattern to give the characteristic shapes of each type of crystal.
  - Challenge students to write new definitions and compare their ideas.
5. Suggested materials for display/discussion:
  - Examples of crystals, crystalline and non- crystalline materials for discussion – students may have examples that they can bring from home, but be careful with any prized specimens.
  - Ball and stick models and/or diagrams of the structures of different substances.

### Background: Why are crystals important to engineers?

Did you know that engineers need to know all about the properties of materials? This means they can design and build or manufacture all kinds of things to be able to do all kinds of different jobs. For example, for a razor blade to keep a sharp edge, it depends on having a crystal-like structure.

Engineers look at structure and bonding in the materials they use. Structure is the way that the tiny particles (such as atoms and molecules) that make up each material are put together. Bonding is how the particles are held together – some bonds are strong, others are quite weak.

Did you know that diamond and graphite are both pure carbon? Diamond is the hardest naturally occurring substance and can be used to cut glass. Graphite, like the lead in your pencil, is soft and slippery. Why are they different? It's because the carbon atoms are held in place in different ways.

Structure and bonding explain how things vary in density, strength and shininess. Some things are easier to cut or shape, some heat up more easily. Some can conduct electricity when others can't.

Understanding crystals and materials with crystal-like structures is very important when you want to use them to make things. When you do these activities you will find out much more about what crystals are, their structures, how they can be grown and even how they can be used to generate electricity!

### Notes

Crystals are characterised by their regular three dimensional shapes, with flat surfaces organised in definite patterns depending on the mineral in question. According to Wikipedia, a crystal or crystalline solid is a solid material whose constituent atoms, molecules, or ions are arranged in an

orderly repeating pattern extending in all three spatial dimensions. The idea of creating a regular, repeating pattern underlies an understanding of how crystals

- can grow
- grow to give specific shapes.

# Growing crystals

Wow your audience by growing crystals right in front of their eyes! Try the following experiments.

You might like to think about using digital cameras, video cameras and projectors to show the experiment.

## 1. Crystals from melts

---

This experiment shows how crystals form from a *melt* (the way most metals are prepared – the molten metal is cooled to make a solid).

### You will need

- water bath (70-80 °C)
- sodium thiosulfate crystals
- test tube and bung

### What you need to do

1. Use the water bath to heat about 10 g of sodium thiosulfate in a test tube. (Add a drop of water if they don't melt easily.)
2. When the crystals have melted, put the bung in the test tube and leave it for a few hours to cool. (If you don't put a bung in the test tube, dust might get in which can ruin the experiment.)
3. Once the liquid is cool, remove the bung and drop a sodium thiosulfate crystal into the test tube.
4. Observe what happens (use a digital microscope if possible).
5. Why does the cool liquid heat up?

## 2. Crystals from vapour

---

This experiment shows how crystals form from a vapour.

### You will need

- two 100 cm<sup>3</sup> beakers
- clamp and stand
- shallow pan, big enough to hold one of the beakers
- water bath (about 50 °C)
- pieces of solid air freshener
- ice
- eye protection

### Health and safety

This should be carried out in a fume cupboard. Check the ingredients of your air freshener – try to avoid one that contains p-dichlorobenzene [HARMFUL, DANGEROUS FOR THE ENVIRONMENT]. Wear eye protection.



### What you need to do

1. Put a few pieces of air freshener in one of the beakers. Place it into the water bath.
2. Put some ice into the second beaker (about two-thirds full).
3. Place the ice-filled beaker on top of the other beaker. Use the clamp and stand to hold it in place – don't just balance it on top!
4. Watch what happens to the pieces of air freshener.

## 3. Crystals from solutions – by evaporation

---

Using this method, you can make tiny crystals in less than 30 minutes. They can only be viewed under a microscope. If you connect the microscope to a camera you could project the experiment onto a screen to act as a backdrop – the audience will be able to watch the crystals grow throughout the show.

### You will need

- light microscope with camera attachment
- glass slides
- a variety of saturated solutions, such as:
  - copper sulfate solution [HARMFUL]
  - iron (II) sulfate solution [HARMFUL]
  - calcium chloride solution [IRRITANT]
  - salt solution
  - sugar solution
- dropping pipettes (for each solution)
- eye protection

### Health and safety

Wear eye protection.

### What you need to do

1. Put a glass slide on the microscope stage.
2. Put a drop of solution onto the slide. Turn on the microscope light.
3. Watch as your crystals appear! Check every couple of minutes. Take a photo if the microscope's connected to a camera, or sketch the shape of the crystals as they appear.
4. Try again with different solutions. Each one should have its own crystal form.

## 4. Crystals from solutions – using electricity

---

It's quite easy to grow crystals using electricity. A simple method follows. Your challenge is to design and make a cell for this experiment so that you can use a projection microscope to show it to your audience.

### **You will need**

- 0-12 V variable voltage supply
- two 4 mm leads
- ammeter
- a pair of electrodes
- lead nitrate solution
- a projection microscope
- a cell to contain the solution – your teacher or organiser should tell you what equipment is available
- eye protection

### **Health and safety**

Lead nitrate solution is toxic if concentrated, so take care when handling, and wash your hands afterwards. Wear eye protection.

### **What you need to do**

1. Your challenge is to first design and build a cell that will contain lead acetate solution.
  - Each electrode should have one end inside the cell.
  - The other ends should be connected to the power supply (positive terminal to the anode; negative terminal to the cathode).
  - You need to be able to sit the cell on top of a microscope stage so the crystal growth can be projected.
2. Once you've built your cell, pass about 45 mA / 10 Volts through the electrodes. You should see some impressive looking crystalline lead growing on one of the electrodes.
3. Now reverse the current. Watch as the lead crystals disappear from one electrode and appear on the other.

## **5. Who can grow the largest crystal from solution?**

---

With a bit of care and attention alum crystals can grow quite large. So, who can grow the biggest, most impressive and beautifully-formed crystal? You could have an audience vote to decide the winner.

### **You will need**

- 100 cm<sup>3</sup> of hot tap water
- 150 g alum (aluminium potassium sulfate)
- 2 clean jars
- paper towel
- elastic band
- string, thread or nylon fishing line
- a rod of some sort – a pencil, piece of dowel or glass stirring rod will all work
- small piece of sticky tape [IRRITANT]
- eye protection

## Health and safety

Wear eye protection. Alum solutions can be acidic.

## What you need to do

1. Pour the hot tap water into a clean jar.
2. Add the alum, bit by bit, while stirring the water. Keep adding alum until the water is saturated – in other words, until the alum stops dissolving.
3. Place the paper towel over the jar and hold it in place with the elastic band. Leave it somewhere safe overnight – make sure it doesn't get disturbed.
4. The next day, pour the liquid from the jar into the second, clean jar. There should be some small crystals left at the bottom. Pick the largest crystal you can find and remove it from the jar.
5. Tie the thread around your crystal – this may be quite tricky, but keep trying and you'll manage it in the end. Tie the other end of the thread to the middle of the rod.
6. Balance the rod on top of the jar that now contains the liquid. Wind it until the thread is dangling the crystal in the middle of the liquid. It shouldn't touch the sides. Once the crystal is in position, use sticky tape to secure the thread to the rod.

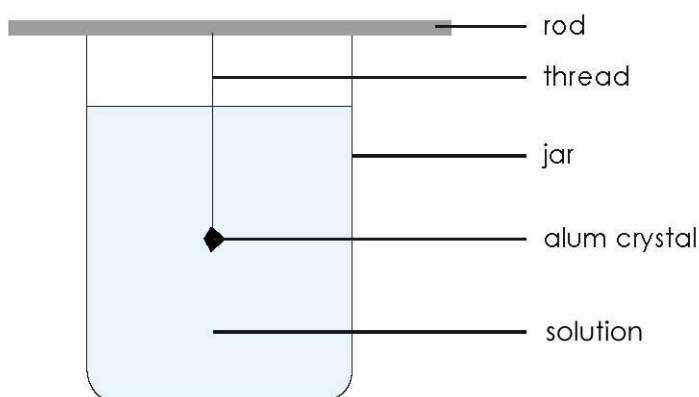

7. Cover the jar with a paper towel and leave the crystal to grow.
8. When you think it's big and beautiful, take it out and impress your friends!

## Top tips

- Try to use nylon fishing line rather than other types of thread – other crystals may grow on string, robbing your crystal of the alum it needs to get bigger!
- If you see other small crystals growing in the jar, take your crystal out (be very careful!), pour the liquid into another clean jar, and re-hang your crystal in it.

# Growing crystals

## ORGANISER'S NOTES

### What do I do?

1. Read through the activity instruction sheet to familiarise yourself with the activities.
2. Check the resources lists and make sure that everything that students need is available. Extra materials may be needed if repeats are necessary.
3. Make sure that students understand the activity – to watch crystals forming and make it possible for others to see the process taking place.
4. Challenge them to
  - use their knowledge of crystal structure and bonding to explain why the crystals form in each case
  - explain why the crystals grow but keep their shape.
5. Give them the equipment and materials that they need and make clear any health and safety issues. If necessary, instruct them in the use of the microscope and any digital imaging equipment. Advise them not to use the high power objective (longest lens) of a standard microscope as:
  - the magnification will be too great to be able to see groups of crystals
  - the depth of focus will be too small – only small parts of the crystals will be in focus at one time
  - it will be very difficult to focus
  - there is a risk of damaging the objective lens if it comes in contact with the slide and solution.
6. If any of the methods 1-4 is unreliable in forming crystals at a fast enough rate, consider using only the best ones, or using time elapse photography for the show.
7. For method 5 (growing a large crystal)
  - to avoid disappointment students could start to grow more than one crystal each
  - it is useful to have a collection of small crystals that can be used for seeding, in case any students fail to find suitable crystals in their solutions. Some may find it too difficult to tie the crystals onto the line and may need assistance from their friends
  - depending on the students, plastic cups or beakers may be safer to use than glassware
  - the thread can be left attached to the crystal so that a label with the owner's name can be fastened to it
  - it is worth trying out this method in advance, to be able to get an idea of the crystal size that can be obtained in a given timescale. If really big crystals are to be grown, more time and larger containers and volumes of solution are needed. A successful large crystal can always be transferred to more solution, to allow it to continue growing.

## Suggested materials

### 1. Crystals from melts

---

- water bath (70-80 °C)
- sodium thiosulfate crystals

- test tube and bung

### Background

Crystals need a solid to grow on. In this case it is the sodium thiosulfate crystal that is added. It is called a seed crystal. Moving particles in the melt have greater kinetic energy than those in a solid. Therefore, they move more quickly. As the liquid cools particles lose kinetic energy and slow down. When their kinetic energy falls below a certain point, the attractive forces between particles cause the particles to bond to one another and form a solid.

## 2. Crystals from vapour

---

- two 100 cm<sup>3</sup> beakers
- clamp and stand
- shallow pan, big enough to hold one of the beakers
- water bath (about 50 °C)
- pieces of solid air freshener – if possible, avoid those containing p-dichlorobenzene [HARMFUL, DANGEROUS FOR THE ENVIRONMENT]
- ice

### Background

This is similar to the formation of crystals from a melt, except that particles in a gas (or vapour) have even more kinetic energy and move faster than particles in a liquid. No seed crystal is used, but tiny bits of dust or other debris provide a growing point for the crystals.

## 3. Crystals from solutions – by evaporation

---

- light microscope with camera attachment (students may try out their own solutions using individual microscopes without the need to project the images). The microscope light source should not be LEDs as this will not generate sufficient heat.
- glass microscope slides
- a variety of saturated solutions, such as:
  - copper sulfate solution [HARMFUL]
  - iron(II) sulfate solution [HARMFUL]
  - calcium chloride solution [IRRITANT] – make up in 1 M sulfuric acid to avoid air oxidation
  - salt solution
  - sugar solution

Solutions are saturated when no more solid crystals will dissolve in them – a few small undissolved crystals may be seen.

- dropping pipettes (use a different pipette for each solution, making sure that students do not mix them up)

### Background

The heat from the microscope light is enough to evaporate the solution, which speeds up the growth of crystals. What happens may be likened to crystals from a vapour, the difference being that the particles are moving around in a solvent. Nonetheless, as the solution cools particles lose energy and eventually bond together to form a solid crystal.

#### 4. Crystals from solutions – using electricity (reduction)

---

- 0-12 V variable voltage supply
- two 4 mm leads
- ammeter
- a pair of electrodes
- lead nitrate solution [TOXIC if > 0.1 M]
- a projection microscope
- a cell to contain the solution
- eye protection

##### Background

Positive lead ions,  $\text{Pb}^{2+}$ , move towards the negative electrode (the cathode). Each ion gains two electrons to form a lead atom. Lead atoms bond together to form crystals of lead.

#### 5. Who can grow the largest crystal from solution?

---

- 100 cm<sup>3</sup> of hot tap water
- 150 g alum (aluminium potassium sulfate) (each 7 cm<sup>3</sup> of water needs about 10 g of alum)
- 2 clean jars
- paper towel
- elastic band
- string, thread or nylon fishing line
- small piece of sticky tape [IRRITANT]
- a rod of some sort – a pencil, piece of dowel or glass stirring rod will all work

Optional: solutions of other compounds could be used, such as copper sulfate [HARMFUL], iron(II) sulfate [HARMFUL], calcium chloride [IRRITANT] or common salt.

##### Background

This is like crystals from solution on a warm microscope slide, only on a much bigger scale

## Health and Safety

A risk assessment should always be carried out before starting any practical work. Students should wear eye protection. Although low hazard, alum solutions are quite acidic ~ pH3.

## Possible extensions

The shapes, sizes and rates of growth of the crystals can be recorded and compared.

Conditions could be altered, for example the choice of compound and the concentration of the solution can be investigated with a view to obtaining the best rate and pattern of crystal growth for projecting throughout the show. Alternatively,



video recording could be used to obtain the best images over the required timescale.

Older students could investigate the effect of cooling rate on crystal size by placing melted salol (phenyl 2-hydroxybenzoate / phenyl salicylate [IRRITANT – wear eye protection]), melted in a test tube in a water bath at about 50 °C\* on microscope slides which have been preheated to about 60 °C, and on slides cooled in a freezer or beaker of ice. Larger crystals should be obtained with slower cooling.

They might also investigate the use of sodium ethanoate in supersaturated solutions in hand warmers. For example, see <http://quest.nasa.gov/space/teachers/microgravity/12rapid.html>.

Information on crystal growing can be found in V Kind, 2004, *Contemporary chemistry for schools and colleges* Royal Society of Chemistry, London, pp 25-30.

\*Note: If the water is heated with a Bunsen burner, temperature control is reduced. Put a plug of cotton wool in the mouth of the test tube, to limit the loss of vapour.

# Modelling crystals

Minerals found in the Earth's crust are crystalline. Crystals are also important engineering and it's all to do with their properties. Can you help the audience to see how the properties of a crystal and the way its particles are arranged are connected?

## 1. Modelling a salt crystal using marshmallows

You will have grown salt (sodium chloride) crystals and seen that they are tiny cubes. How can you explain why they have this shape?

### You will need

- 30 mini-marshmallows: 15 white to represent sodium ions and 15 pink to represent chloride ions
- cocktail sticks, each broken in half

### What you need to do

Work in two groups. You need the same number of people in each group.

Group 1: Each person should make three layers of the model by joining the marshmallows like this, using the half sticks as bonds:

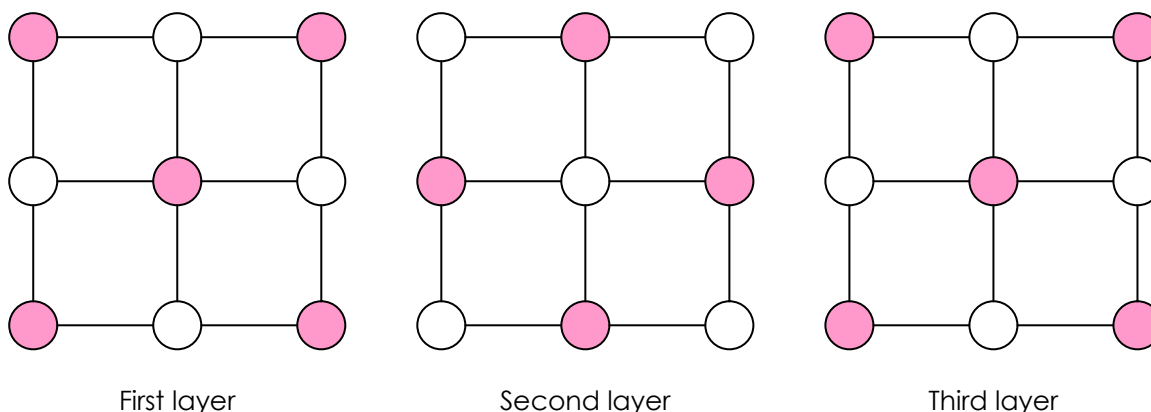

Now join the three layers, again using half sticks.

Group 2: Make three layers of the model by joining the marshmallows like this, using the half sticks as bonds:

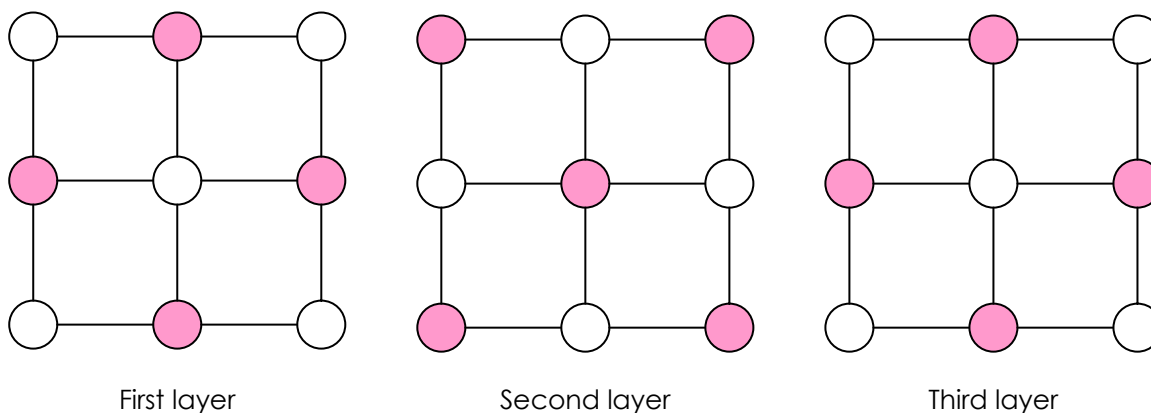

Now join the three layers, again using half sticks.



Bringing the models together: Finally, connect up the two unit cells, to show how a crystal grows.

## 2. Modelling crystals using cardboard shapes

---

Crystals of naturally occurring crystals fall into one of seven types (called crystal systems). You can represent the building blocks of each type by making 3D cardboard shapes. Knowing these shapes can help geologists identify minerals.

### You will need

- plan for the crystal shape
- scissors
- steel rule
- model knife and cutting board
- fast-drying glue (or double sided sticky tape)
- access to the Internet

### What you need to do

Work in a group of at least three. Each person will have a piece of stiff card with the plan for a different crystal shape. Here are the instructions to make a model:

1. Cut out the plan. You could use scissors, but a more accurate model can be made by using a steel ruler and a model knife to cut out the shape.
2. Score along the internal lines using a steel ruler and a model knife (use the back of the blade) and, one at a time, fold **up** along the dashed lines and **down** along the solid ones.
3. Now fold the plan to fit the model together and decide where to glue it.
4. Unfold your model and use fast-drying glue to stick the tabs to their adjacent faces. Now assemble your model and hold it gently while the glue dries.
5. Look at your model and decide which of the seven crystal systems it represents. (You will be given a prompt sheet to help you)
6. Search the internet to find examples of naturally occurring minerals with crystals belonging to the crystal system you have made.

Using your models as props, describe to the audience how the crystal shapes differ from one another. Say how this helps to identify minerals.

## 3. Modelling diamond and graphite

---

Diamond is the hardest natural substance. Engineers use it for cutting and grinding tools. Graphite is soft and has a slippery feel. It's what pencil lead is made of. Yet both diamond and graphite are made only of carbon. Use marshmallows to show how the property of a material depends on its structure.

### You will need

- 30 white (or pink) mini-marshmallows
- cocktail sticks, each broken in half

### What you need to do

Work in pairs. One person makes a model of diamond. The other makes a model of graphite.

This is the structure of diamond:



Make a model of it using the marshmallows and sticks.

This is the structure of graphite:

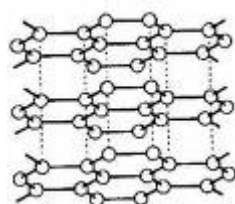

Make a model of it using the marshmallows and sticks.

Use the models to explain the different properties of diamond and graphite.

## 4. Modelling crystal growth using people

---

With all this impressive crystal growing, and modelling of crystals it would be nice if you could give the audience an explanation of how crystals form. One way to do this is to model the process – using people! You could either put on the demonstration yourself, or use audience members to help out.

### What you need to do

#### Crystals from the melt

Some crystalline substances melt to form a liquid. When this liquid cools crystals form again. Metals are a good example, and the process of getting crystals from the melt is really important for engineers. Indeed, they can change the properties of a metal by the way the process of cooling is controlled.

1. You need to know the difference between how particles are arranged and move in a solid and in a liquid. You may have come across the particle model. If not, find out about it.
2. You can model melting like this:

Ask nine people to stand in a pattern like this, close to one another, just touching, and then move so that they are half a metre away from each other.

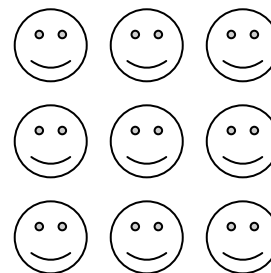

Get them to jiggle around, gently bumping into one another, but always keep their overall shape. Now turn on an imaginary Bunsen burner. The jigging needs to get faster. On the trigger MELT, ask them to start moving randomly, still about half a metre away from one another, but no longer in a fixed pattern. They now represent particles in a liquid.

Note: If you want to model boiling, turn up the imaginary burner and on the trigger BOIL to begin to break away from one another and occupy the full space of the room. Their movement should be fast and random. They now represent particles in a gas.

3. On the basis of the description above, work out how to use members of the audience to model crystal formation from a melt.
4. Crystallisation starts from a single point. However, there are always many of these points so that crystals start growing in different places. Each area of growth is called a grain and where two crystals meet is called a grain boundary. These are really important in determining the properties of, for example, metals. If you feel ambitious you could try to model this!

# Modelling crystals

## ORGANISER'S NOTES

### What do I do?

1. Read through the activity instruction sheet to familiarise yourself with the activities.
2. Check the resources list and make sure that everything that students need is available.
3. Make sure that students understand the activity – to use models to demonstrate and explain crystal structure and how crystals form.

### Suggested materials

#### 1. Modelling a salt crystal using marshmallows

---

- 30 mini-marshmallows: 15 white to represent sodium ions and 15 pink to represent chloride ions
- cocktail sticks, each broken in half

##### Background

The shape of a crystal is determined by the way its particles (atoms, ions or molecules) are arranged in space and bonded to one another. In sodium chloride the particles are sodium ions,  $\text{Na}^+$ , and chloride ions,  $\text{Cl}^-$ . The marshmallow model shows an 'exploded' lattice. In fact, the ions pack together so that they touch one another.

#### 2. Modelling crystals using cardboard shapes

---

- plans for the crystal shapes (see: <http://fortran.orpheusweb.co.uk/Models/CrClas.htm#models>)
- scissors
- steel rule
- model knife
- fast-drying glue
- access to the Internet

##### Background

Crystals fall into one of seven crystals systems. These are differentiated by the lengths of their sides and the angles between faces. The building blocks of these crystals systems can be represented by making 3D cardboard shapes. Crystal growth may be modelled by fitting building blocks together. If this is done, you will find that blocks representing a crystal system fit together leaving no gaps.

#### 3. Modelling diamond and graphite

---

- 30 white (or pink) mini-marshmallows
- cocktail sticks, each broken in half

##### Background

Diamond has a giant three-dimensional lattice. All bonds are equally strong. Graphite consists of layers of strongly bonded carbon atoms, but the bonds between one layer and another are relatively weak, so the layers slide over one another easily.

#### 4. Modelling crystal growth using people

##### Background

As a liquid cools, its particles start to slow down and their kinetic energy decreases. Eventually the kinetic energy is less than the attractive forces between particles, so rather than keep moving they begin to bind together to form a solid.

##### Health and Safety

A risk assessment should always be carried out before starting any practical work.

##### Possible extensions

Crystal growth and dissolving crystals allows students to explore the concepts of solid, liquid, solution, solvent, dissolving and crystallisation. Students could construct their own models to show crystal shapes or how particles fit together to form crystals. Older students could be challenged to build larger more permanent models of crystal structure.



Dry crystals often contain water as part of their structure. Washing soda crystals (hydrated sodium carbonate) or hydrated sodium sulfate will lose water vapour when exposed to the atmosphere. Students can record and graph small changes in mass and describe alterations in appearance. Glass-like crystals of washing soda turn into a dull white powder.

Students could study the 'creeping' effect of various solutions of salts left in open containers. Crystals start to form around the edges at the surface of the solution. As the solution rises up the sides by capillary action, a crystal crust forms which can reach the top of the container and continue down the outside. The white powdery deposit that often forms on new brick walls is due to this type of movement of salts.

# More about crystals

## 1. Crystalline or plastic?

---

Some substances can be crystalline or plastic depending on how they are made. The element sulfur is a good example. It would be difficult to demonstrate the formation of crystalline and plastic sulfur to a live audience of any size, so could you make a short video to show the audience and then get them to model what they see?

### You will need

- two boiling tubes, two test-tube holders and a test-tube rack
- two stands and clamps
- 250 cm<sup>3</sup> conical flask with cork to fit
- an oil bath (1 dm<sup>3</sup> beaker two-thirds full with cooking oil), it should be about 130 °C
- 250 cm<sup>3</sup> beaker half-filled with water
- 250 °C thermometer
- four watch glasses
- two electric hotplates **or** Bunsen burner, tripod and gauze
- two heat resistant mats
- filter paper, about 18 - 20 cm diameter, made into a cone held in shape with a paper clip and a 250 cm<sup>3</sup> beaker for the cone to stand in
- spatula
- 100 g powdered sulfur
- 100 cm<sup>3</sup> dimethylbenzene [HARMFUL]
- eye protection

You will also need a digital video camera to record the demonstration and a way to project images of small crystals.

### Health and safety

Wear eye protection. Use heat resistant gloves when handling hot materials. Carry out the preparations in a fume cupboard. Keep a damp cloth handy to extinguish small sulfur fires.

### What you need to do

You need to work under the guidance of a teacher or another person experienced in laboratory work.

#### To make crystals of monoclinic sulfur

1. Put about 20 g of powdered sulfur into a boiling tube and stand the tube in the oil bath. The sulfur should be below the level of the oil
2. When the sulfur has melted (it forms a transparent, amber liquid in about 15 minutes) pour the molten sulfur into the filter paper cone. Allow the sulfur to cool slowly and solidify. A crust will form.
3. Wearing heat resistant gloves to hold the filter paper, break the crust with a spatula and tilt it to pour out any remaining liquid onto a piece of scrap paper (for disposal). Needle-shaped crystals of monoclinic sulfur will be seen inside the hollow cone.

### To make plastic sulfur

1. Put about 20 g of powdered sulfur into a boiling tube and stand the tube in the oil bath. When the sulfur has melted, remove the tube from the hot oil using a test-tube holder. Wipe off any oil using a paper towel.
2. Heat the molten sulfur gently over a small Bunsen flame, keeping the contents moving to prevent local overheating. The liquid gets darker and, fairly suddenly, becomes a viscous, gel-like substance. This occurs at about 200 °C. Continue to heat the sulfur slowly until it becomes runny again. It will form a very dark red-brown liquid.

During this heating, the sulfur may catch fire and sulfur dioxide will be produced. Have a damp cloth handy to place over the mouth of the tube to extinguish the flames.

3. When the sulfur begins to boil, pour the liquid in a slow stream into a beaker of cold water. A tangled mass of brown plastic sulfur will form. Allow it to cool thoroughly.
4. Remove the plastic sulfur from the water and show that it is rubbery – it can be stretched and will return to its original shape.

### To make crystals of rhombic sulfur

1. Gently warm the conical flask containing 10 g sulfur and 100 cm<sup>3</sup> dimethylbenzene to about 50°C (preferably on an electric hotplate) to dissolve the sulfur.
2. Pour a little of the solution into each of a set of watchglasses and leave them in the fume cupboard for the solvent to evaporate. This will take about 10 minutes. Small crystals of rhombic sulfur form.

## **2. Make a crystal garden**

---

Who can make the most impressive, colourful crystal garden? You could present this like a cookery show. Show your audience the ingredients and method – then produce one you made earlier. (But make sure no-one tries eating your crystals!)

### **What you will need**

- sand
- 600 cm<sup>3</sup> beaker (or similar-sized glass container)
- 100 cm<sup>3</sup> sodium silicate solution
- 400 cm<sup>3</sup> water
- forceps
- crystals of metal salts (it's up to you which you choose, depending on which colours you want):
  - White – calcium chloride [IRRITANT]
  - White – lead(II) nitrate [TOXIC]
  - Purple – manganese(II) chloride [HARMFUL]
  - Blue – copper(II) sulfate [HARMFUL]
  - Red – cobalt(II) chloride [TOXIC]
  - Orange – iron(III) chloride [HARMFUL]
  - Yellow – iron(III) chloride [HARMFUL]
  - Green – nickel(II) nitrate [HARMFUL and OXIDISING]
- eye protection

**Health and safety**

Wear eye protection. Use the forceps, not your fingers.

**What you need to do**

1. Pour sand into your beaker to create a thin layer at the bottom.
2. Mix the sodium silicate solution and water together. Pour the mixture into the beaker.
3. Using forceps only – no fingers - add whichever crystals you want, but don't add too many.
4. Watch your chemical garden grow! It should start to grow within fifteen minutes or so. If you leave it, it should continue to get bigger, so leave it somewhere safe overnight.

**You might like to try**

- Adding more or less crystals, to work out the ideal number for a brilliant garden.



# More about crystals

## ORGANISER'S NOTES

### What do I do?

1. Read through the activity instruction sheet to familiarise yourself with the activities.
2. Check the resources list and make sure that everything that students need is available.
3. Make sure that students understand the activity

### Suggested materials

#### 1. Crystalline or plastic?

---

- two boiling tubes, two test-tube holders and a test-tube rack
- two stands and clamps
- 250 cm<sup>3</sup> conical flask with cork to fit
- an oil bath (1 dm<sup>3</sup> beaker two-thirds full with cooking oil), it should be about 130 °C
- 250 cm<sup>3</sup> beaker half-filled with water
- 250 °C thermometer
- four watch glasses
- two electric hotplates **or** Bunsen burner, tripod and gauze
- two heat resistant mats
- filter paper, about 18 - 20 cm diameter, made into a cone held in shape with a paper clip and a 250 cm<sup>3</sup> beaker to stand the cone in
- spatula
- 100 g powdered sulfur
- 100 cm<sup>3</sup> dimethylbenzene [HARMFUL]
- eye protection
- digital video camera to record the demonstration and a way to project images of small crystals.
- access to a fume cupboard

#### Background – what's happening?

Scientists often talk about the 'degree of crystallinity' of a polymer – it has a marked effect on properties. The higher the degree of crystallinity the less flexible and more brittle the material becomes. Two forms of sulfur are crystalline – rhombic and monoclinic. A third form, called plastic sulfur, is not crystalline.

### Notes

- These preparations must be carried out in a fume cupboard and require very close supervision. It may be preferred for the organiser to demonstrate and the students to film.
- For more information about this practical, see <http://www.practicalchemistry.org/experiments/allotropes-of-sulfur,264,EX.html>

## 2. Make a crystal garden

---

- sand
- 600 cm<sup>3</sup> beaker (or similar-sized glass container)
- 100 cm<sup>3</sup> sodium silicate solution [CORROSIVE] – sold as waterglass, egg preservative. If the solution is not available, do **not** try to make it by dissolving the powder.
- 400 cm<sup>3</sup> water
- forceps
- crystals of these metal salts (to allow colours to be chosen by students)
  - White – calcium chloride [IRRITANT]
  - White – lead(II) nitrate [TOXIC]
  - Purple – manganese(II) chloride [HARMFUL]
  - Blue – copper(II) sulfate [HARMFUL]
  - Red – cobalt(II) chloride [TOXIC]
  - Orange – hydrated iron(III) chloride [HARMFUL]
  - Yellow – hydrated iron(III) chloride [HARMFUL]
  - Green – nickel(II) nitrate [HARMFUL and OXIDISING]
- eye protection

NOTE: These metal salts are reasonably soluble in water. If a particular metal is not available from the list, the nitrate is usually a suitable alternative. Detailed background can be found at <http://www.bbc.co.uk/ouch/messageboards/A4044845>.

### Background

The science here is a little complicated. The outside of each crystal reacts with the sodium silicate solution to produce a coating of an insoluble metal silicate, e.g. a copper sulfate crystal becomes coated in copper silicate. The metal silicate is porous and water from the solution can get through. This forms a solution of copper sulfate which bursts through the coating, only to react with sodium silicate again. And so the process goes on.

## Health and Safety

A risk assessment should always be carried out before starting any practical work. Students are very likely to be tempted to use their fingers, especially if they drop the crystals from the forceps. If this seems likely, gloves should be used, as some of the chemicals are skin sensitive. Students should wear eye protection. See the notes about making plastic sulfur.

## Possible extensions

Older students could experiment with different methods. An approach using food colourings can allow different coloured crystals to be produced in imaginative arrays. Porous materials like blotting paper and cardboard can be cut into shapes through which the solution can be drawn by capillary action. Coloured dyes can be spotted on the edges of these shapes to give arrays of crystal growth of contrasting colours. Details of a method to make a crystal tree can be found at <http://www.chymist.com/Crystal tree.pdf>. The 'household ammonia' is a 5% solution and the 'laundry bluing' is a weak colloid of iron(II,III)



hexacyanoferrate(II,III). Sources of laundry blueing are given at <http://www.oldandinteresting.com/buy-laundry-blue.aspx>. Time elapse photography is a good way to record the growing crystals. See for example <http://www.youtube.com/watch?v=sj9LFoy2PSQ&feature=related> or <http://www.youtube.com/watch?v=LX2csTQ76gY>

# Putting crystals to use

## 1. Crystals and microphones

---

In this cool activity you can make your own microphone. It uses piezoelectric crystals.

You can then see who's made the best microphone by using a member of the audience to judge which produces the best sound.

A good way could be to read a poem and see if an audience member can write down exactly what you said. To keep in with the show's "Earth" theme, you could write a poem about physical weathering. Carry out the physical weathering experiments, below, and use your findings to help write the poem.

### You will need

- tin can or a *Pringles* tube (the bottom of the tin or tube must have a flat section big enough for the piezo transducer you are going to use)
- 1 x piezo transducer
- some wire (thin stranded instrument wire is best)
- multi-purpose glue or double sided sticky tape
- electrical insulation tape
- amplifier with loudspeaker
- pair of wire strippers and cutters
- ¼ inch audio lead, cut in half
- access to mains electricity supply

### Health and safety

If you are using a tin can, choose one with a pull-off top. This saves using a tin-opener and produces a safer edge. Make sure that the tin is thoroughly cleaned and dried before use.

### What you need to do

1. Remove the top of the can or remove the lid, if you are using a tube. Take care with sharp edges; *Pringles* tubes or drinking chocolate drums are much easier to handle.
2. Clean the can or tube.
3. Stick the piezo element to the bottom of your tin or tube. The simplest way to do this is with double-sided sticky tape, but you can use multi-purpose glue. Make sure that the two wires attached to the piezo transducer are on the top.



4. Use the wire strippers to strip about 3 cm of plastic covering from the end of both leads.
5. Now prepare the audio lead ...

- Strip some of the plastic covering from the end of the audio lead. Inside you should see a clear plastic tube with a wire inside, covered with lots of thin strands of wire. The cross section should look a bit like this:

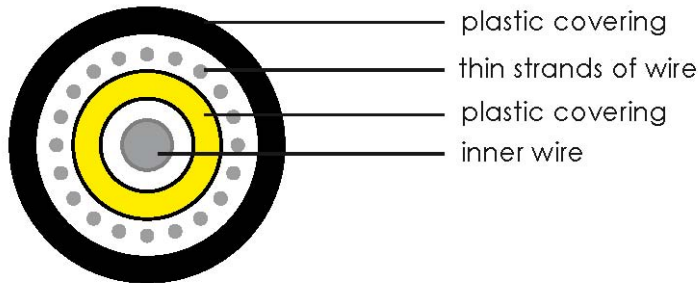

- Carefully peel away the thin strands of wire and twist them together to form a single wire.
- Now use the wire strippers to remove about 3 cm of the clear plastic tube.
- Connect your microphone leads to the audio lead by twisting the red lead together with the thin strands, and the black lead together with the other wire.
- Plug the other end of the audio lead into the amplifier and connect to the electricity supply.
- Test your microphone.

### **Physical weathering experiments – to help write your poem**

---

Use the following short activities to gather information, then write a poem (or song) about physical weathering. You may wish to do some extra research to help you.

You could read your poem – or perform your song – for your show. Alternatively, you could use your poem to test a piezoelectric microphone. If members of the audience can hear every word, then you've been successful (and you've taught them something as well!)

#### **Freeze-thaw action – happens when water gets into a crack in a rock and freezes.**

- Fill a glass jar with water. Screw on the lid and place it inside a plastic box with a lid.
- Put the jar in a freezer and leave until the next day.
- Carefully take the box out of the freezer and look at the jar. Do not touch the glass.
- What has happened to the jar? Explain this process, imagining that the jar represents a crack in a rock.
- Put the lid back on the box and dispose of it safely as instructed by your teacher.

#### **Exfoliation – happens in places where there are extreme temperature changes, such as a desert.**

- Wearing eye protection, use tongs to heat a small piece of rock over a blue Bunsen flame for about five minutes. Stop heating if it begins to 'pop'.
- Drop the rock into a bucket of cold water. Describe what happens.
- Take it out, dry it, and repeat the process up to five more times.

#### **Abrasion – water or wind carrying grains of sand or rock scours of pieces of larger rocks as it passes**

- Make some plaster of Paris cubes in an ice cube tray. Do not touch the plaster mixture – it may get very hot.
- Place the set cubes in a plastic food container, with a lid.

3. Shake them about for a few seconds. Have a look at them and write down what they look like.
4. Shake them a few more times, record your observations after each shake.
5. How does abrasion physically weather rocks? How does their shape change?

## 2. Memory metal

---

Here's a demonstration using the amazing Nitinol. This should impress the audience!

### What you need

- Nitinol spring
- large glass bowl - Pyrex
- hot water (not quite boiling – about 80 °C) in a kettle [CARE]

### Health and safety

Stand up while carrying out this experiment. Wear eye protection. Take care with the very hot water.

### What you need to do

1. Stretch the Nitinol spring.
2. Put the stretched spring in the bowl.
3. Pour over the water and watch what happens.

### Working it into your show

Ask an audience member to stretch the spring and put it in the bowl. Tell them you will turn it back into its original form without touching it. Then pour on the hot water ...

## 3. Lift with a spring

---

Impress the audience with a spring that lifts a kilogram load. It's all to do with crystalline structures.

### What you will need

- clamp, stand and boss
- 100 g mass hanger and nine 100 g slotted masses (total of 1 kg)
- 2 x crocodile clips
- high current power pack
- two 4 mm leads
- coil of Nitinol wire
- two pieces of string or thread, both tied into small loops

### Health and safety

Warning: the springs will get hot.

### What you need to do

1. Set up the clamp, stand and boss. Make sure that the clampstand will not tip over when a heavy load is hung from the spring.
2. Stretch the coil of Nitinol wire so that its length is 10 cm.

3. Hang the Nitinol coil from the clamp by one of the string loops.
4. Hang the mass hanger from the end of the other string loop. This gives it a load of 100 g.

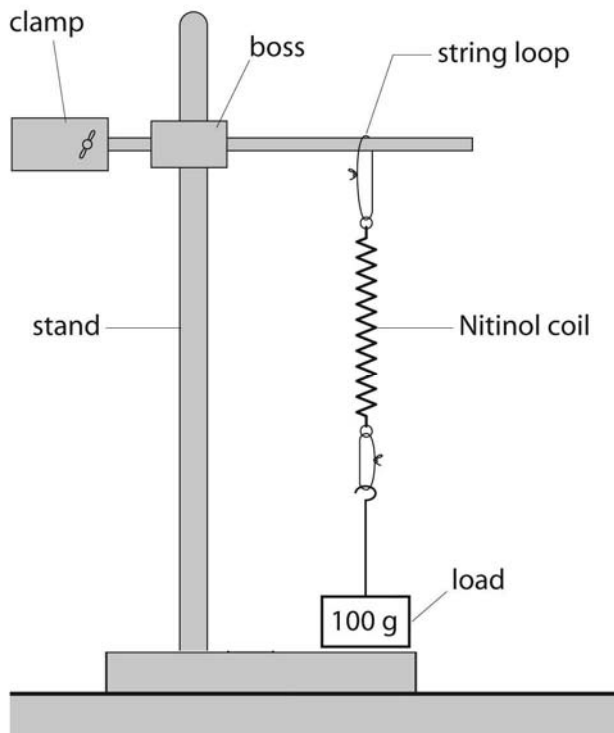

5. Adjust the height of the clamp so the mass is just above the bench – not touching it.
6. Set up the electrical circuit. Use the yellow terminals of the power pack.

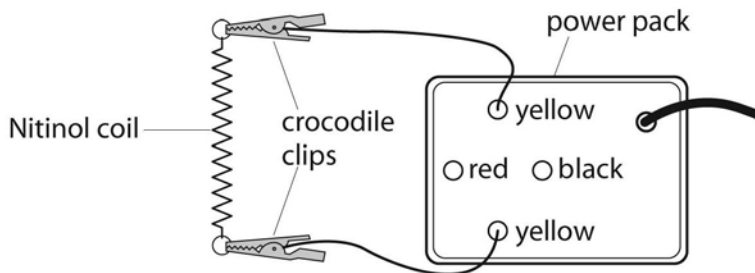

7. Turn on the power pack and start the stopwatch.
8. Observe what happens to the spring. Was that what you expected?
9. Blow on the coil to cool it down. Then pull the mass down until it rests just above the bench.
10. Repeat the experiment, adding more masses each time.

### Working it into your show

Set up three or four sets of apparatus, using springs made of different metals (make sure the last one has a Nitinol spring). Ask the audience what will happen when you turn on the power pack. Many will know that most metals expand when they get hot. By the time they reach the Nitinol wire they will be confident in their prediction. So imagine their surprise when the kilogram mass is lifted into the air!

# Putting crystals to use

## ORGANISER'S NOTES

### What do I do?

1. Read through the activity instruction sheet to familiarise yourself with the activities.
2. Check the resources lists and make sure that everything that students need is available. Extra materials may be needed if repeats are necessary.
3. Make sure that students understand the activity – to demonstrate unusual uses of crystal structures. The 'microphone' activity also suggests broadcasting a song or poem to test the microphone – the topic of physical weathering is suggested, and experiments to help gather information are provided.
4. Give them the equipment and materials that they need and make clear any health and safety issues. Dispose of any broken glass carefully – if a plastic box such as an ice cream tub is used in the freezing experiment, this may be used to keep fragments safe.

### Suggested materials

#### 1. Crystals and microphones

---

- tin can or a *Pringles* tube (the bottom of the tin or tube must have a flat section big enough for the piezo transducer)
- one piezo transducer
- some wire (thin stranded instrument wire is best)
- multi-purpose glue or double sided sticky tape
- electrical insulation tape
- amplifier with loudspeaker [PAT-tested]
- pair of wire strippers and cutters
- ¼ inch audio lead, cut in half
- access to mains electricity supply

#### Background

Piezoelectricity: crystals generate a voltage when a mechanical stress is applied to them. You've probably come across piezoelectric crystals in lighters for gas fires or cookers. Squeezing a trigger or pressing a button puts pressure on the piezoelectric crystal and it produces a voltage. The reverse effect is possible – if you apply a voltage to a piezoelectric crystal it changes size slightly.

#### Physical weathering experiments

- glass jar screw top jar
- plastic box with lid, large enough to put the jar in
- freezer
- eye protection
- tongs
- small piece of limestone



- Bunsen burner
- bucket
- cold water

### **Abrasion**

- plaster of Paris
- water
- container and stirrer for mixing the plaster
- ice cube tray
- plastic food container with a lid

## **2. Memory metal**

---

- a Nitinol spring (from [www.MUTR.co.uk](http://www.MUTR.co.uk))
- large Pyrex bowl
- hot water (not quite boiling – about 80 °C) in a kettle [CARE – consider how it will be poured]

### **Background**

Nitinol wire is an alloy of nickel and titanium. It has two types of crystal structure, depending on whether it is above or below its critical temperature. Below the critical temperature, the alloy is flexible and can be bent easily into any shape. But once heated to the critical temperature, it transforms into its original state, where the atoms become locked into their previous rigid arrangement.

## **3. Liff with a spring**

---

- clamp, stand and boss
- 100 g mass hanger and nine 100 g slotted masses (total of 1 kg)
- 2 x crocodile clips
- high current power pack
- two 4 mm leads
- coil of Nitinol wire
- two pieces of string or thread, both tied into small loops

### **Background**

Nitinol wire is an alloy of nickel and titanium. It has two types of crystal structure, depending on whether it is above or below its critical temperature. Below the critical temperature, the alloy is flexible and can be bent easily into any shape. Once heated to the critical temperature, it transforms and the atoms lock into their previous rigid arrangement.

Passing an electric current through the wire raises its temperature. As it goes above its critical temperature, the atoms move closer together. In doing so, it lifts the mass – it does work.

## **Health and Safety**

A risk assessment should always be carried out before starting any practical work. Give students instructions on how to deal with disposal of the broken glass (weathering demonstration). In Liff with

a spring, there is a risk of the clamp and stand tipping over, when the heavy load is suspended from the Nitinol. Make sure that the long side of the base is parallel to, and directly below, the clamp arm.

### **Possible extensions**

Using an electric current to heat Nitinol wire could be exploited by using the wire to move a lever to perform an action of some kind.



# Thank you for using Rockin' Crystals

We hope you enjoyed the activities within this pack. To help us to continue to provide new activity packs, we'd like to ask you to tell us a little about what you did for National Science & Engineering Week.

Please take a few minutes to fill in this form. If you used this challenge pack for NSEW, send in this completed form and we will send you a National Science and Engineering Week Certificate.

Organisation:

Address:

Postcode:

Tel:

Email:

Which dates did you do National Science and Engineering Week activities on?

What did you do?

Please make any comments about this activity pack, National Science & Engineering Week and/or other possible topics for future packs.

**Tick this box** to be added to our mailing list. This will keep you up to date with NSEW, including grants, resources and activities. Your contact details will not be passed onto third parties.

**Please return to:**

**Fax: 0870 770 7102**

**Post: National Science & Engineering Week**

**FREEPOST LON 20848**

**London**

**SW7 5BR**